



THOROUGHCLEAN
WATER BLASTERS

P6R-30CS, P6R-30CD and P6R-20C Portable Petrol Water Pressure Cleaner

The ThoroughClean P6R portable petrol pressure cleaner range demands high pressure and/or flow in a rugged, tough and over-engineered machine that will outlast any other water blaster

HONDA



Thoroughclean Water Blasters
www.thoroughclean.com.au



Petrol Driven



Cold Water



Medium usage

Distributed by:



1300 378 872
 sales@trhc.com.au
 www.trhc.com.au
 12-14 Ashburn Road
 Ipswich Qld 4304

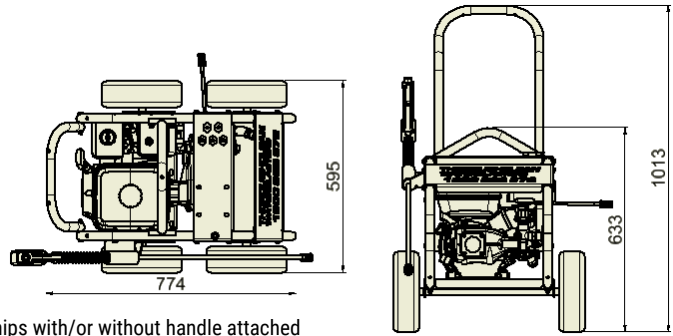

NB: Ships with/without handle attached

STANDARD EQUIPMENT



Spray Gun -
310 bar 30 lpm

900mm Lance /
Nozzle
- Lance with 4 x
stainless steel snap
nozzles and 1 x
chemical nozzle.

Hose - 10m of 3/8"
steel dual braided
hose.

OPTIONAL ACCESSORIES

Hose reel	P6R-30CS
Detergent injector	P6R-20C

TYPICAL APPLICATIONS

- Car/Bike Wash Downs
- Path Cleaning
- Agricultural Equipment
- Car and Equipment Yards
- Concrete Landscaping
- Small Workshops
- Lawn and Handyman Contractors
- Residential Cleaning
- Schools
- Tradies

**Derating (or de-rating or de-tuning) is the operation of a machine at less than its rated maximum power in order to prolong its life. The term is commonly applied to [electrical](#) and [electronic devices](#) and to [internal combustion engines](#)

ANALYSIS - DESIGN
 CONSTRUCTION - ACCESSORIES

DISCLAIMER: All images are a representation only and are not to scale. Although care has been taken to ensure the accuracy, completeness and reliability of the information provided, due to ongoing product development and improvements, products may vary from this data sheet. The user of the information agrees that the information is subject to change without notice.

Product Code	p/n	P6R-30CS	P6R-30CD	P6C-20C
--------------	-----	----------	----------	---------

TECHNICAL DATA				
Working Pressure	psi / bar	2900/200	2900/200	2000/137
Flow Rate	l/pm	9.5	10	13
Max Water Inlet Temp	°c / °f	65/149	65/149	65/149
Class (AS/NZS 4233.1:2013)	grade	A	A	A

INTENDED APPLICATION

Usage Frequency	hours / type	Light	Medium	Medium
-----------------	--------------	-------	--------	--------

Motor

Engine	type	Honda GX200	Honda GX200	Honda GX200
Power	hp	5.8	5.8	5.8
Fuel Supply	type	Petrol	Petrol	Petrol
Fuel Capacity	litres	3.1	3.1	3.1
Low Oil Shutdown	y / n	N	N	N
Starting System	type	Recoil Start	Recoil Start	Recoil Start

Pump & Hydraulics

Pump / Head / Pistons	Make	Hawk	Hawk	Hawk
Rated Pressure	psi/bar	2900/200	2900/200	2175/150
Motor Pump Coupling	type	Direct	Gearbox	Gearbox
Pump Speed	rpm	3400	1450	1450
Filter System	type	Inline	Inline	Industrial
Unloader valve	y / n	Y	Y	Y
Orifice / Nozzle	size	30	30	30

OTHER FEATURES

Hose Length	mts	10	10	10
Hose Reel Included	y / n	Option	Y	N/A
Frame Structure	type	Galvanised	Galvanised	Galvanised
Lifting Point	y / n	Y	Y	Y
Detergent Injector	y / n	Y	Y	Option

DIMENSIONS & WEIGHT

Approx Weight	kg	58	65	66
Length	mm	774	774	710
Width	mm	595	595	636
Height	mm	1013	1013	630

WARRANTY(S)

Motor Warranty	year(s)	3	3	3
Pump Warranty	year(s)	1	1	1
Frame Warranty	year(s)	5	5	5